

# Distributed Electrostatic Micro Actuator

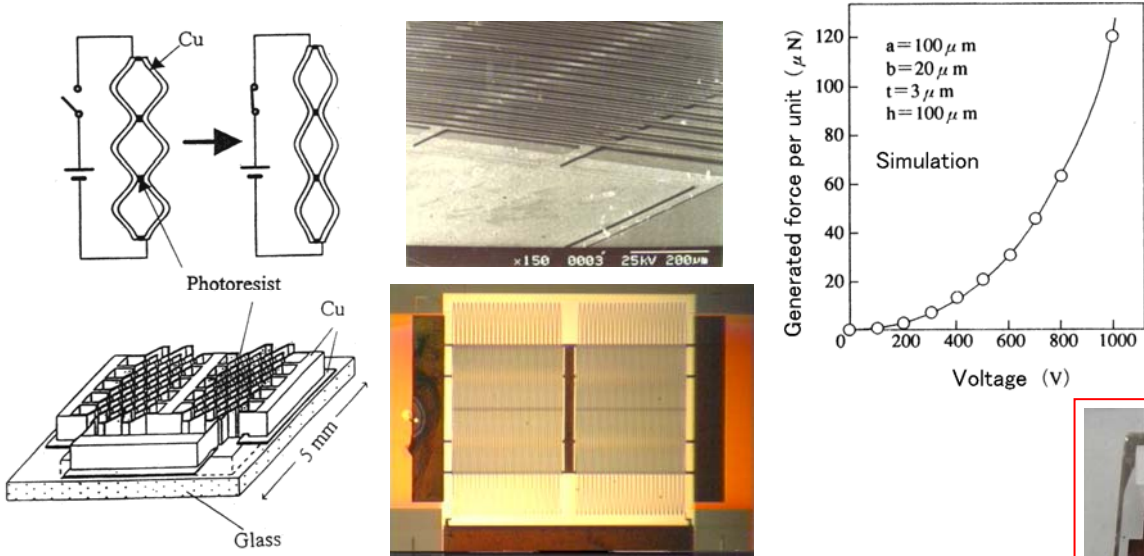

Distributed electrostatic micro actuator

Reference : K.Minami, S.Kawamura and M.Esashi, Fabrication of Distributed Electrostatic Micro Actuator, IEEE Journal of Micromechanical Systems, 2 (1993) pp.121-127

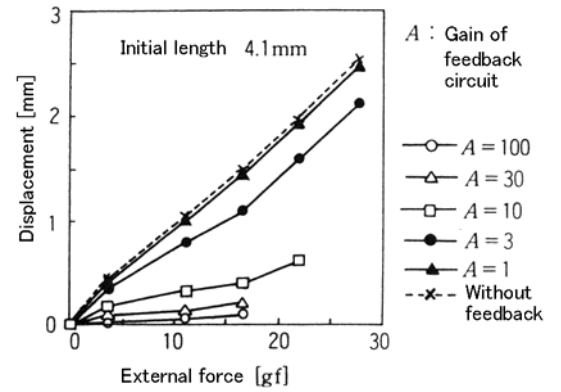
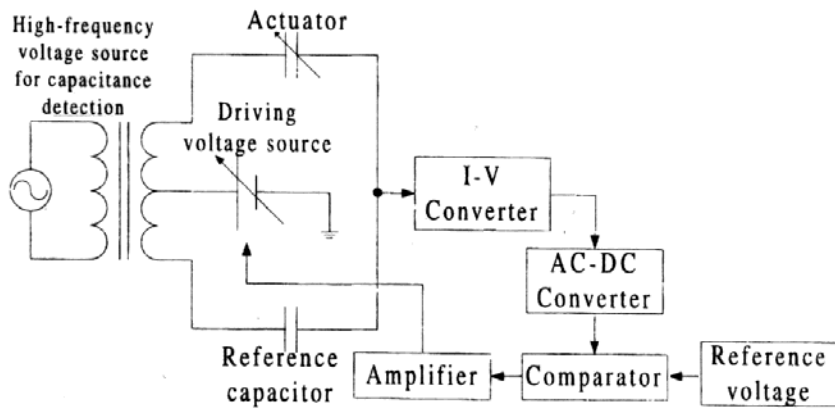

Compliance control of distributed electrostatic microstructure

Reference : M.Yamaguchi, S.Kawamura, K.Minami and M.Esashi, Control of Distributed Electrostatic Microstructures, Journal of Micromechanics and Microengineering, 3 (1993) pp.90-95

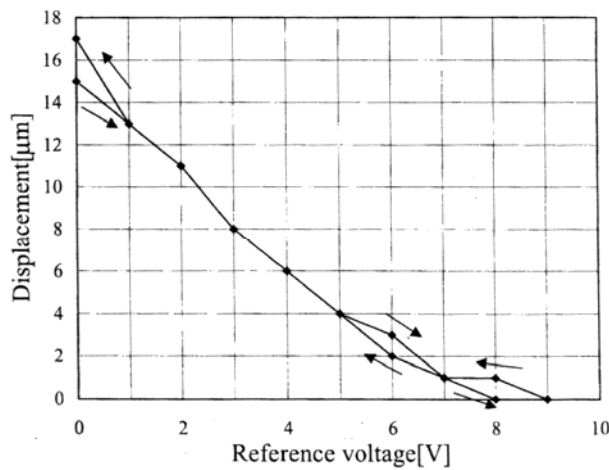
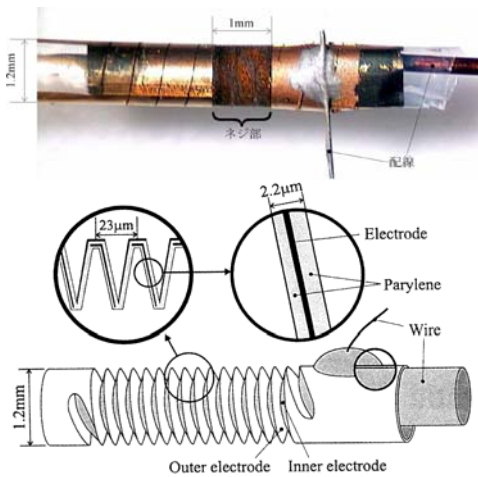

Bellows-shape electrostatic microactuator

Reference : K.Minami, H.Morishita and M.Esashi, A Bellows-shape Electrostatic Microactuator, Sensors and Actuators, 72 (1999) pp.269-276