

RF MEMS (田中, 江刺 他)

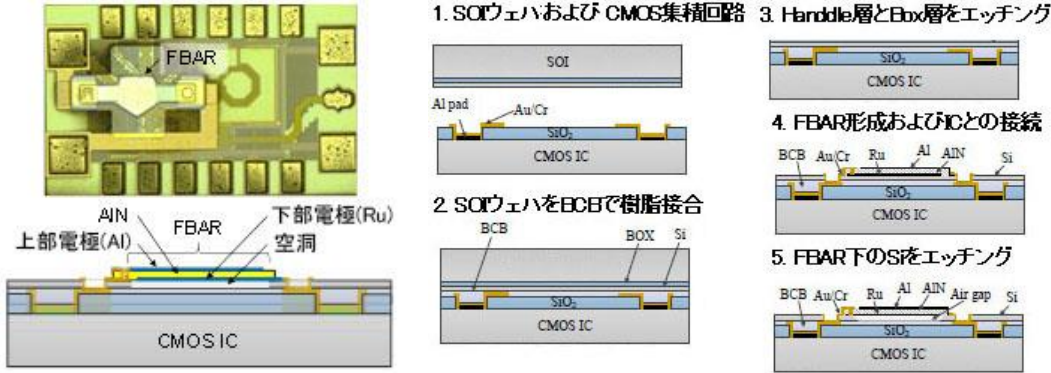

LSI 上に製作した FBAR (film bulk acoustic resonator) (Kochhar et. al, 2012 IEEE Internl. Ultrasonic Symp. (2012) 1047)

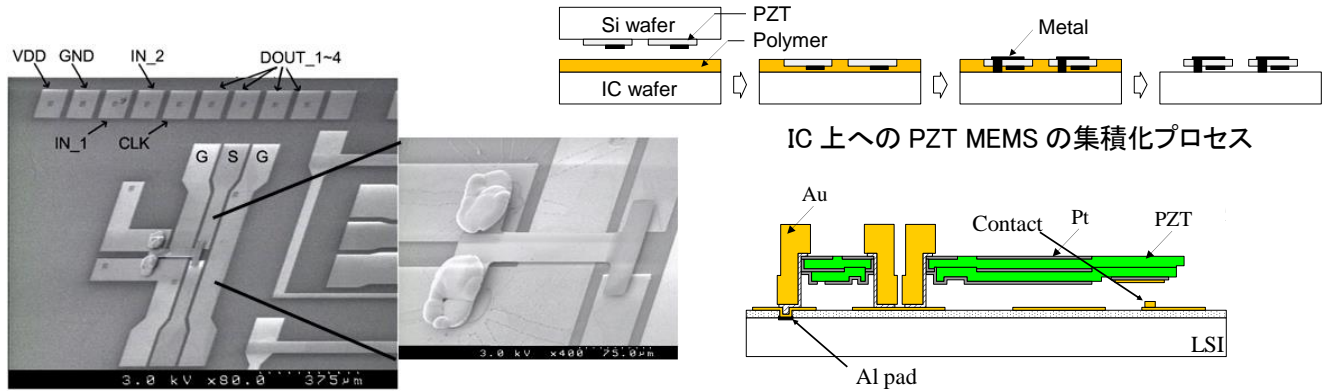

0.35 μm CMOS 上に作製した PZT 圧電駆動 MEMS スイッチ (Matsuo et al., IEEE MEMS 2012, pp. 1153-1156)

PZT 圧電駆動 MEMS スイッチの断面構造

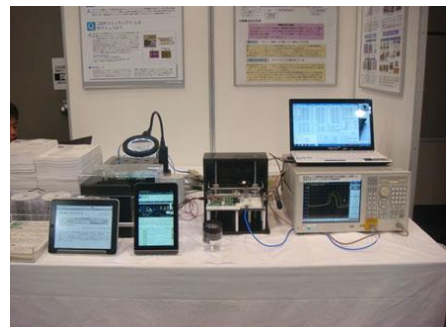
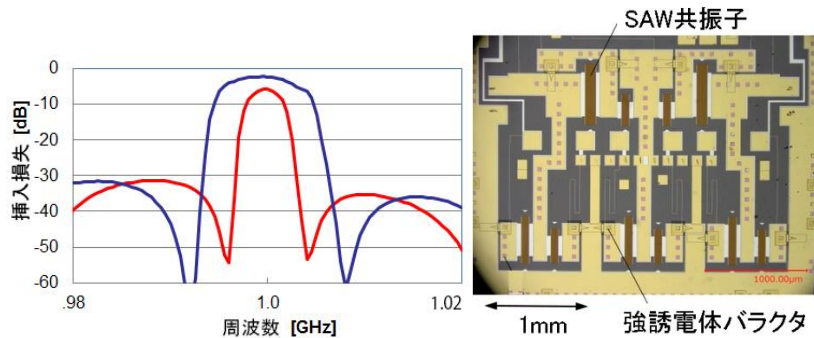
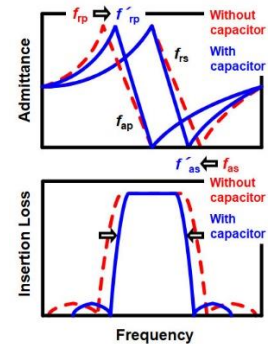
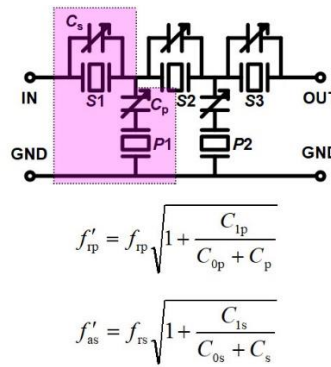
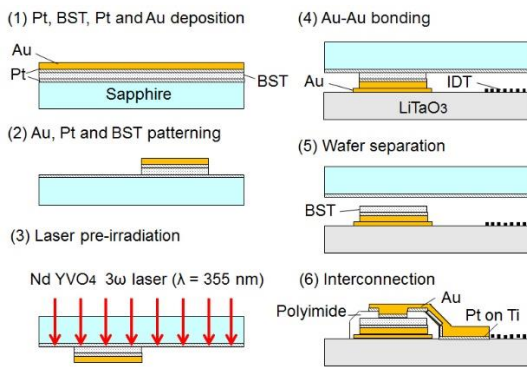

SAW デバイスへの強誘電体可変容量素子の選択転写による可変帯域フィルタ

(H.Hirano et.al, J. of Micromech. Microeng., 23, 2 (2013) 025005(9pp))